

ADVERTISING RATES

DISPLAY (including GST)

Editions	Casual *	incl GST	3 editions *	incl GST	6 editions *	incl GST	12 editions*	incl GST
Double Page spread IFC	\$3,730	\$4,103	\$3,475	\$3,822.50	\$3,190	\$3,509	\$2,890	\$3,179
Inside Front cover	\$2,920	\$3,212	\$2,780	\$3,058	\$2,420	\$2,662	\$2,190	\$2,409
Inside Back cover	\$2,640	\$2,904	\$2,490	\$2,739	\$2,220	\$2,442	\$2,045	\$2,249.50
Outside Back cover	\$2,920	\$3,212	\$2,780	\$3,058	\$2,420	\$2,662	\$2,190	\$2,490
Double Page spread	\$2,984	\$3,282.40	\$2,780	\$3,058	\$2,552	\$2,807.20	\$2,312	\$2,543.20
Full page	\$2,045	\$2,249.50	\$1,935	\$2,128.50	\$1,760	\$1,936	\$1,605	\$1,765.50
Half page	\$1,230	\$1,353	\$1,175	\$1,292.50	\$970	\$1,067	\$880	\$968
Third page	\$860	\$946	\$805	\$885.50	\$640	\$704	\$605	\$665.50
Quarter page	\$600	\$660	\$560	\$616	\$460	\$506	\$405	\$445.50
Eighth page	\$350	\$385	\$310	\$341	\$280	\$308	\$250	\$275

* All prices listed are per issue.

- Flysheet Rate on request.
- Insert Rates on request.

DEADLINES

Issue	*Booking & cancellation deadline	Material deadline	On Sale
August/September 2011	20 June	11 July	10 August
October/November 2011	22 August	12 September	12 October
December/January 2011/12	21 October	11 November	14 December

* Please note that deadlines and rates are subject to change and advertisers will be notified in advance

For more information call

Geoff Halpin T: 02 8741 6843 M: 0412 541 183 F: 02 8741 6697 E: geoff.halpin@mynrma.com.au

ADVERTISING RATES

CLASSIFIEDS (excluding GST)

Editions	Casual	+ GST	4/5 editions	+ GST	6+ editions	+ GST
1/4 page	\$750	(\$825)	\$635 per issue	(\$698.50)	\$450 per issue	(\$495)
1/8 page	\$410	(\$451)	\$335 per issue	(\$368.50)	\$275 per issue	(\$302.50)
1/16 page	\$235	(\$258.50)	\$180 per issue	(\$198)	\$120 per issue	(\$132)

DEALER ADVERTISING PACKAGE (excluding GST)

Magazine Dealer ads + Website banner advert	+ GST	
1 page print + banner	\$1,200	(\$1,320)
1/2 page print	\$700	(\$770)
1/4 page print	\$450	(\$495)

Dealer advertisements in the Classified section

Banner ad web site link on Australian Caravan + RV web site www.caravanandrv.com.au

- Insert Rates on request.

DEADLINES

Issue	*Booking & cancellation deadline	Material deadline	On Sale
August/September 2011	20 June	11 July	10 August
October/November 2011	22 August	12 September	12 October
December/January 2011/12	21 October	11 November	14 December

* Please note that deadlines and rates are subject to change and advertisers will be notified in advance

For more information call

Geoff Halpin T: 02 8741 6843 M: 0412 541 183 F: 02 8741 6697 E: geoff.halpin@mynrma.com.au

MECHANICAL SPECIFICATIONS

	Trim Size	Type Area	Bleed Size
Double page Spread	420mm (w) x 297mm (d)	410mm (w) x 287mm (d)	430mm (w) x 307mm (d)
Full Page	210mm (w) x 297mm (d)	200mm (w) x 287mm (d)	220mm (w) x 307mm (d)
Half Page Horizontal	190 mm (w) x 135 mm (d)	n/a	n/a
Half Page Vertical	90 mm (w) x 277 mm (d)	n/a	n/a
1/16 page	45 mm (w) x 60 mm (d)	n/a	n/a
1/8 page	95 mm (w) x 60 mm (d)	n/a	n/a
1/4 page	95 mm (w) x 125 mm (d)	n/a	n/a

TECHNICAL SPECIFICATIONS

NRMA Publishing accepts only digital material. All material must be supplied formatted for the Apple Macintosh OSX platform. All images should be of a high resolution (eg. 300dpi JPEG format).

We accept files saved in the following formats:

Adobe Photoshop at 300dpi or larger (saved as EPS, JPEG, TIFF or PSD) Adobe Illustrator saved as EPS files up to Version 11.0 Adobe Indesign documents up to Version 13.0 PDF files at 300dpi or better.

NB. artwork embedded in or saved as MS Word or PowerPoint documents or files will not be accepted. We do not accept Truetype fonts. Crop marks and 5mm of bleed around artwork must be included on display advertisements.

Delivery formats:

CD-ROM / DVD- ROM
Email
Quickcut
Websend

Proofs:

All material must be accompanied by a suitable high quality colour proof (Chemical, IRIS, High Resolution Digital). No responsibility will be taken for colour matching, material integrity or finished advertisement print quality if a colour proof is not supplied.

Material delivery:

Clearly mark all material with Australian Caravan + RV and the month of publication.

Send to:

Australian Caravan + RV

NRMA
Level 1
9 George Street
North Strathfield NSW 2137

Email: jo@openroad.com.au

PUBLISHERS' CONDITIONS

Payment required within 30 days of publication. Agency commission 10% of gross. Cancellation of booked advertising cannot be accepted after booking confirmation closing date. Publishers are not responsible for errors due to changes made after material closing date. Rates given are on the basis that space ordered is used within 12 months and that material supplied as per conditions set out hererin. All copy is subject to the approval of the publishers. When the copy is overdue, the publishers reserve the right to repeat previous copy. The publishers reserve the right to reject or cancel any advertising at any time for any reason. If an advertiser has booked advertising and fails to deliver copy by the copy deadline, the advertiser will be charged the full advertising rate as if the advertisement had run (excludes earlier notice of cancellation before copy deadline).

INSERT SPECIFICATIONS

Magazine trim size	297 mm (d) x 210 mm (w)
Minimum supply size	100 mm x 100 mm
Maximum supply size	275 mm x 190 mm

If an insert exceeds 16 pages, the above dimensions may not be suitable. Please consult Production prior to proceeding.

Minimum weight of paper

Single sheet, minimum size	100 gsm
Single sheet, maximum size	90 gsm
Four page folder	60 gsm
Eight pages or more	60 gsm

Folding

Folded inserts must have a “closed” or leading edge to enable automatic feeding on the collator. Concertina folds are not suitable. The above information is intended as a guide only.

It may be possible to insert products which fall outside these guidelines and we will be able to advise on the suitability of any samples submitted.

Contacts

Advertising: Geoff Halpin **T:** 02 8741 6843 **M:** 0412 541 183 **F:** 02 8741 6697 **E:** geoff.halpin@mynrma.com.au

Production: Jo McIntyre **T:** 02 8741 6683 **F:** 02 8741 6698 **E:** jo@openroad.com.au

INSERT SPECIFICATIONS

Delivery instructions

Packaging

Pallets will be accepted where they meet the following guidelines:

- Bundle turns to be between 120-160 mm.
- All pallets must not exceed maximum weight of 110kg.
- Pallet size of 1165 x 1165.
- All pallets to be in good condition and securely wrapped.
- For smaller deliveries skids are acceptable.
- Cartons are to be no heavier than 20kg.
- Cartons must be sealed and labeled with Contents and Quantities.
- Delivery dockets must be supplied for all deliveries.
- Delivery times: Between 7 am - 4.30 pm.

Terms and conditions

*All bookings are subject to the Terms and Conditions of Advertising.

*If inserts fail to arrive in time for publication, if cancelled after the specified deadline or are cancelled due to any deviation from the technical specifications then the full rate will be charged.

Labelling instructions

All product must arrive labelled including the following:

- Australian Caravan+RV Magazine
- Insert title
- Issue date
- Total quantity expected
- Quantity per pallet/carton
- Total number of pallets/cartons
- Key number where applicable

Freight Instructions

Deliver all material to:

Offset Alpine Printing
42 Borea Street
Lidcombe NSW 2141

Attention: John Blake
Phone: (02) 9704 4444

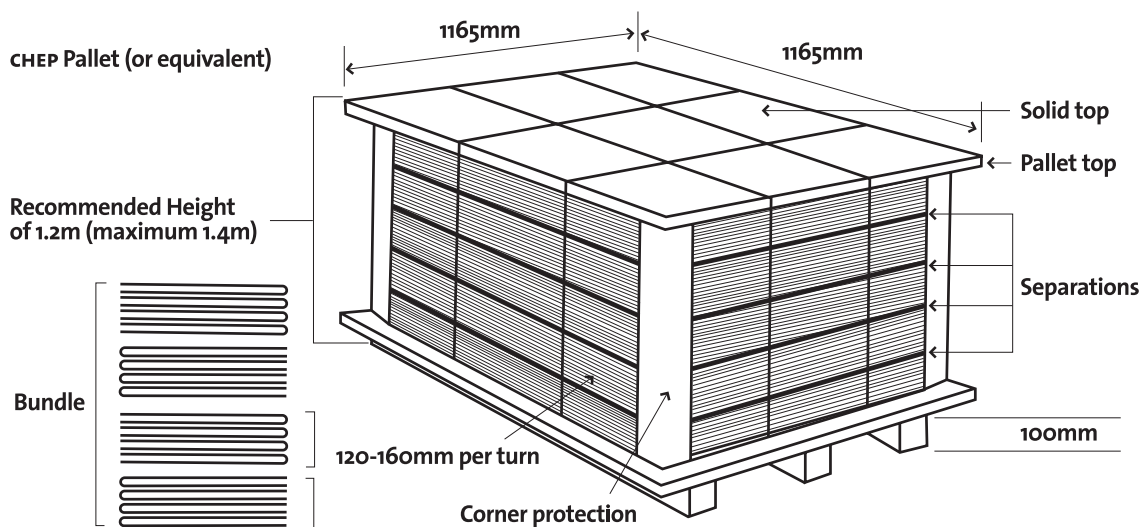

SUPPLIER

TO

OFFSET ALPINE PRINTING
42 BOREA STREET
LIDCOMBE NSW 2141

ATTN: JOHN BLAKE
(02) 9704 4444

CLIENT NAME

INSERT / PRODUCT NAME

MAGAZINE NAME

AUSTRALIAN CARAVAN+RV

ISSUE / MONTH (S)

QUANTITY ON PALLET

PROGRESSIVE DELIVERY / QTY

PLEASE TICK

FULL DELIVERY / QTY

PALLET NO.

_____ OF _____

VERSION / CODE / STATE

CHECKED BY SUPERVISOR _____ DATE _____